

Substrate Integrated Waveguide Power Divider Fed Dual-Dipole Array Antenna

Chen Yu · Wei Hong · Zhenqi Kuai

Abstract

In the paper, a printed dual-dipole array antenna is presented. A 4-way planar SIW power divider is adopted for feeding the array antenna. The dual-dipole is adopted as radiation elements which greatly improves the impedance band. The measured bandwidth larger than 31 % for $VSWR \leq 1.5$ operating near 14 GHz is achieved and in agreement with the simulated results. The radiation E-plane and H-plane radiation pattern is presented in the paper. The radiation gain is also presented in the paper.

Key words: SIW, Dipole, Array Antenna.

I. Introduction

Today, many commercial wireless communication systems require low-cost microwave passive components and antennas. Dipoles as radiation cells have merits of low weight, easy to fabricate, and they also offer relatively wide bandwidths and good radiation performance^{[1],[2]}. Printed dipole radiators are popular candidates for array antennas because of their suitability for integrating with microwave integrated circuit^{[3][4]}.

Single dipole has the relatively narrow bandwidth. Some special method has been adopted to expand the dipole bandwidth such as employing double-side dipoles, adding some stubs for impedance matching or adopting special planar balun as feeding system^{[5]~[8]}. Dual-dipole can be adopted as radiation cells to improve the impedance bandwidth and radiation gain^[9].

Substrate integrated waveguide(SIW) has merits of low cost, low profile and easily integrated with planar circuits. A lot of components have been derived from SIW architecture such as filter, power divider etc. Some SIW power dividers have been reported^{[10]~[12]}.

In this paper, a 1×4 array antenna fed by SIW power divider is presented. The printed dual-dipole is adopted as the radiation element. The antenna has been fabricated by using standard PCB process. The influence of various parameters on antenna characteristics is described, and the simulation and measurement results are present.

II. Antenna Structure and Design

In the design, the printed dual-dipole is adopted as the

radiation element. The top side and the bottom side of the dual-dipole are shown in Fig. 1.

The printed dual-dipole would get wider bandwidth than a single printed dipole. The resonant frequencies of two dipoles with different lengths are lower or higher than the center frequency. Here the center frequency is 14 GHz. Two dipoles are connected directly by the printed symmetrical-dual-line. The resonant frequencies of two dipoles overlay to form a wider impedance band, and the bandwidth can be maximized by optimizing the lengths of two dipoles and the distance between them. The length of the dipole controls the resonance frequency of the dipole. The width of the dipole will affect the beamwidth and the resonance frequency of the dipole. A good design rule for the dipole length is 0.47 times the wavelength^[11]:

$$length_{Dipole} = 0.47v / f \quad (1)$$

$$v = c / \sqrt{\epsilon_{eff}} \quad (2)$$

$$\epsilon_{eff} = (\epsilon_r + 1) / 2 + (\epsilon_r - 1) [(1 + 12h/w)^{-1/2} + 0.04(1 - w/h)^2] / 2 \quad (3)$$

Here, ϵ_{eff} is the relative dielectric constant of the substrate, h is the thickness of the substrate and w is the width of the dipole.

The length and the width of the printed symmetrical-dual-line connecting two dipoles should be designed carefully to improve impedance match with the dual dipole and optimized the radiation characteristics.

Comparing with a single dipole, the dual-dipole increases the antenna directivity and radiation gain in the end-

Manuscript received April 14, 2010 ; revised August 20, 2010. (ID No. 20100414-04J)

State Key Laboratory of Millimeter Waves, School of Information Science and Engineering, Southeast University, Nanjing P. R. China.

Corresponding Author : Chen Yu (e-mail : chenyu@emfield.org)

fire direction over a wide frequency range.

In this design, Rogers 5880 with thickness of 0.508 mm and dielectric constant of 2.2 is adopted as the substrate. As shown in Fig. 1. $L_1=5$ mm and $L_2=4.1$ mm are the lengths of two dipoles, respectively, and $W_1=0.5$ mm and $W_2=0.5$ mm is the widths of two dipoles, respectively. The distance between two dipoles is $S=2.1$ mm, and the width of the printed symmetrical-dual-line is 0.7 mm.

The printed symmetrical-dual-line connecting two dipoles connects with the output port of the SIW power divider by a printed tapering symmetrical-dual-line for impedance matching as shown in Fig. 1 and Fig. 2. $WW=3.5$ mm is the width of the end of the printed tapering symmetrical-dual-line connecting with the 4-way SIW power dividers.

Some multi-way SIW power dividers have been reported. In this paper, a 4-way planar SIW power divider has been presented to feed the 1×4 array antenna. In previous papers, SIW right-angle bend transmission line is used in the corner part. In the design, SIW arc transmission line has been adopted instead of SIW right-angle bend transmission line to extend the impedance band as shown in Fig. 2. Here the width of the SIW is 10.5 mm. This 4-way planar SIW power divider can cover from 11.07 GHz to 19.03 GHz for $VSWR \leq 1.5$ in simulation results.

The array structure will improve the radiation gain and control the radiation pattern. The 1×4 array antenna will obtain about 5~6 dB gain more than one single radiation element and narrow the E-plane beamwidth.

The array antenna has been optimized in CST Microwave Studio.

III. Simulation and Measurement

The presented array antenna has been fabricated by

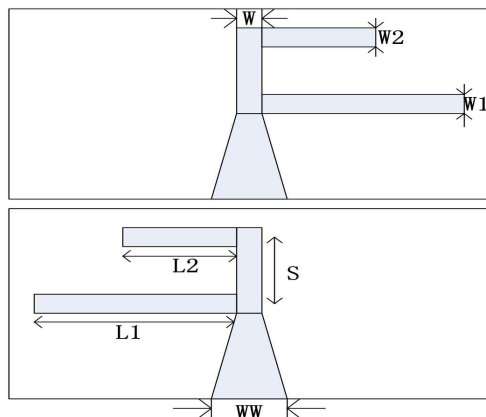

Fig. 1. The structure of the single radiation element.

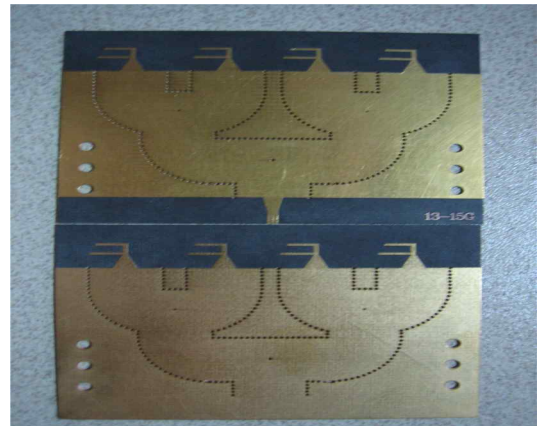

Fig. 2. The photograph of the presented array antenna.

standard PCB process. A photograph of the top side and the bottom side of the presented array antenna is shown in Fig. 2. The impedance bandwidth has been measured with vector network analyzer and the radiation patterns and gains have been measured in anechoic chamber.

The simulated and measured impedance bandwidth of the 1×4 array antenna is shown in Fig. 3. The measurement S_{11} is in agreement with the simulated result. The measured impedance bandwidth for $VSWR \leq 1.5$ is from 12.1 GHz to 16.6 GHz and the bandwidth is about 31 %.

The E-plane and H-plane radiation patterns of the array antenna at 13 GHz, 14 GHz and 15 GHz are shown in Figs. 4~9. It is concluded that the array antenna has the stable radiation patterns at different frequencies. The array structure would narrow the E-plane beamwidth. The 3 dB beamwidth of E-plane of array antenna is 19.2° , 17.8° and 18.7° at 13 GHz, 14 GHz and 15 GHz, respectively.

The gain of the dual-dipole array antenna 11.3 dB, 10.1 dB and 10.1 dB at 13 GHz, 14 GHz and 15 GHz, respectively.

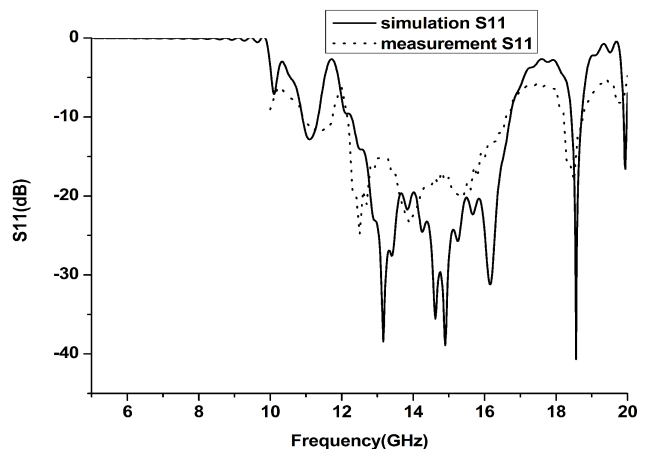

Fig. 3. The simulated and measured S_{11} of the array antenna.

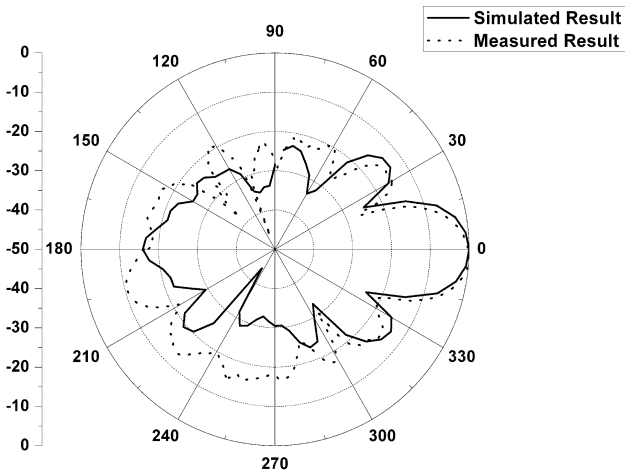

Fig. 4. The E-plane radiation patterns of the array antenna at 13 GHz.

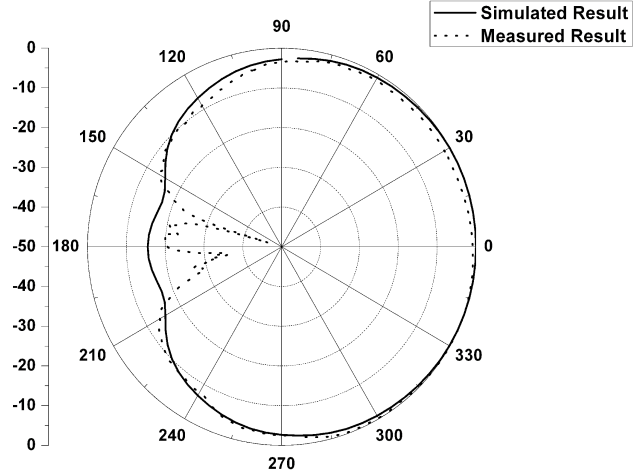

Fig. 7. The H-plane radiation patterns of the array antenna at 14 GHz.

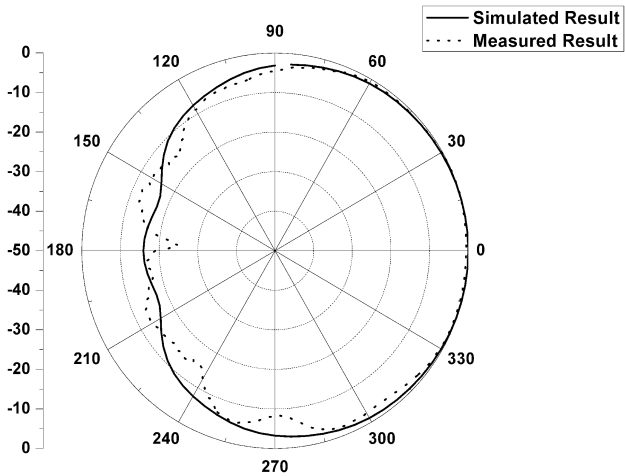

Fig. 5. The H-plane radiation patterns of the array antenna at 13 GHz.

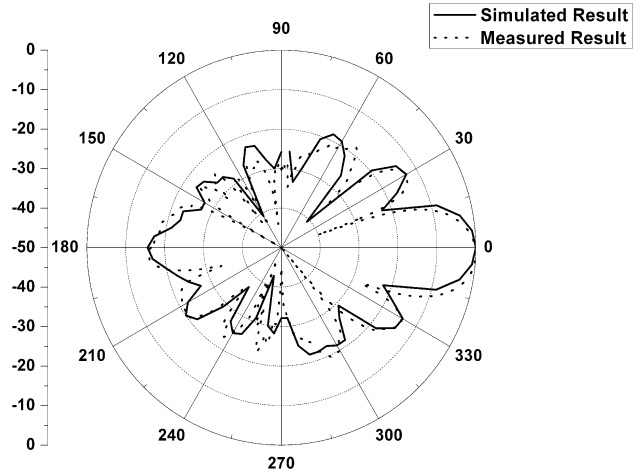

Fig. 8. The E-plane radiation patterns of the array antenna at 15 GHz.

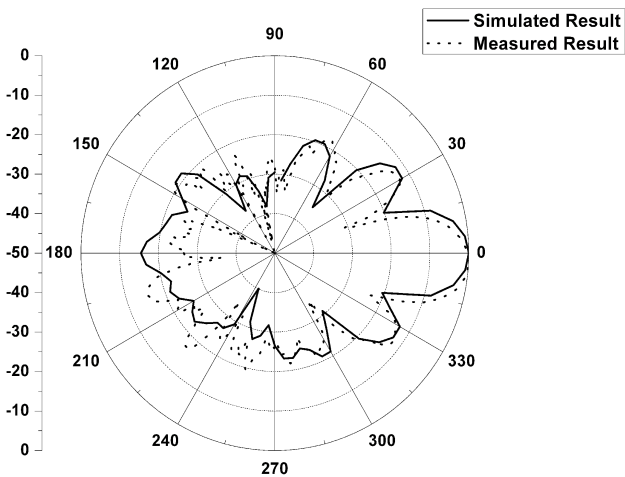

Fig. 6. The E-plane radiation patterns of the array antenna at 14 GHz.

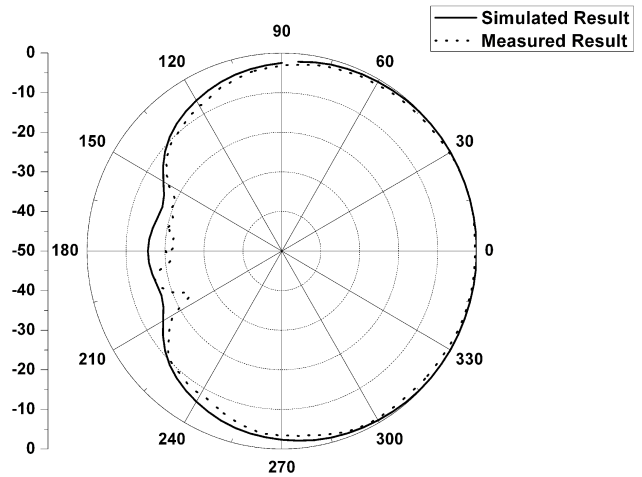

Fig. 9. The H-plane radiation patterns of the array antenna at 15 GHz.

IV. Conclusion

A 1×4 array antenna consists of printed dual-dipole elements and fed by SIW power divider is presented, simulated and measured in the letter. The dual-dipole is adopted to improve the bandwidth. The impedance bandwidth of 31 % and stable radiation patterns are achieved.

This work was supported in part by the National High-Tech Project under Grant 2009AA011801 and in part by NSFC under Grant 60621002.

References

- [1] W. L. Stutzman, G. A. Thiele, *Antenna Theory and Design*, 2nd ed. New York: Wiley, 1997.
- [2] K. Fujimoto, Kyohei Fujimoto, *Mobile Antenna System Handbook*, Artech House, Boston, MA, 1994.
- [3] E. Levine, S. Shtrikman, and D. Treves, "Double-sided printed arrays with large bandwidth", *Proc. Inst. Elect. Eng. Microwave-Opt. Antennas*, vol. 135, pp. 54-59, Feb. 1988.
- [4] C. Yu, W. Hong, and Z. Q. Kuai, "Substrate integrated waveguide fed printed dipole array antenna for isolation the RF front-end from the antenna", *Microwave and Optical Technolog Letters*, vol. 51, pp. 557-562, Feb. 2009.
- [5] R. C. Hua, T. G. Ma, "A printed dipole antenna for ultra high frequency(UHF) radio frequency identification(RFID) handheld reader", *IEEE Trans. on Antennas and Propagation*, vol. 55, no. 12, pp. 3742-3745, Dec. 2007.
- [6] J. F. Huang, J. W. Liang, "Printed and double-sided dipole array antennas with a parallel reflector", *Microwave and Optical Technolog Letters*, vol. 50, pp. 595-600, Mar. 2008.
- [7] G. Y. Chen, J. S. Sun, "A printed dipole antenna with microstrip tapered balun", *Microwave and Optical Technolog Letters*, vol. 40, pp. 344-346, Feb. 2004.
- [8] Z. G. Xiao, H. L. Xu, "A double-sided printed dipole array with an electromagnetic band-gap reflector", *J. Infrared Milli Terahz Waves*, vol. 30, pp. 423-431, 2009.
- [9] T. Fatou, A. G. Craig, "Design of broad-band and dual-band antennas comprised of series-fed printed-strip dipole pairs", *IEEE Trans. on Antennas and Propagation*, vol. 48, no. 6, pp. 895-900, Jun. 2000.
- [10] A. S. Nathan, R. Abhari, "Compact substrate integrated waveguide Wilkinson power dividers", *Proc. IEEE Antennas Propag. Soc. Int. Symp.*, pp. 1-4, Jun. 2009.
- [11] Multi-layer four-way out-of-phase power divider for substrate integrated waveguide applications, *Proc. IEEE MTT-S*, pp. 477-480, Jun. 2009.
- [12] Y. P. Huang, Y. L. Lu, "Design of a substrate integrated waveguide based 1-to-6 non-uniform power divider", *Proc. APMC*, pp. 1-4, Dec. 2008.