

Highly Linear 2-Stage Doherty Power Amplifier Using GaN MMIC

Seunghoon Jee · Juyeon Lee · Seokhyeon Kim · Yunsik Park · Bumman Kim*

Abstract

A power amplifier (PA) for a femto-cell base station should be highly efficient, linear and small. The efficiency for amplification of a high peak-to-average power ratio (PAPR) signal was improved by designing an asymmetric Doherty PA (DPA). The linearity was improved by applying third-order inter-modulation (IM3) cancellation method. A small size is achieved by designing the DPA using GaN MMIC process. The implemented 2-stage DPA delivers a power-added efficiency (PAE) of 38.6% and a gain of 33.4 dB with an average power of 34.2 dBm for a 7.2 dB PAPR 10 MHz bandwidth LTE signal at 2.14 GHz.

Key Words: Digital Predistortion (DPD), Doherty Power Amplifier (DPA), Gallium nitride (GaN), Long-Term Evolution (LTE), Monolithic Microwave Integrated Circuit (MMIC).

I. INTRODUCTION

The demand is currently increasing for small-cell base stations, such as pico-cell and femto-cell to improve system capacity and flexibility. The power amplifier (PA) in small-cell base stations consumes a large portion of the system power and volume. Therefore, the PA should be efficient and small.

A linear amplification of the high peak-to-average power ratio (PAPR) signal should be achieved by operating the PA for the system in a large back-off output power region, where the PA shows a poor efficiency. The efficiency around the average output power level has been enhanced by the introduction of several efficiency enhancement techniques have been introduced, such as envelope elimination and restoration (EER), envelope tracking (ET), and Doherty power amplifier (DPA) techniques [1–4]. Among these techniques, DPA, which employs a load impedance modulation technique, has been widely used in the base station due to its simple structure and high efficiency at the

average output power region.

The DPA is usually implemented with a hybrid configuration in the base stations. In the hybrid PA, the matching network is too large to be useful for the small-cell base station. A limitation also exists on selecting the sizes of the carrier and peaking cells for the DPA due to the device availability. For these reasons, we design a DPA using monolithic microwave integrated circuit (MMIC) process to get a small size and proper cell size ratio of the carrier and peaking PAs for an optimized operation [5, 6]. The highest efficiency for a LTE signal with 7.2-dB PAPR is obtained by applying an asymmetric Doherty structure [7, 8].

The digital predistortion (DPD) technique is widely used for the base station to linearize the PA. However, the DPD circuit board consumes a lot of power for the small-cell base station. Therefore, the DPA should have high linearity in order to linearize the PA using a light PD system. To get a high linearity, third-order inter-modulation (IM3) cancellation method is applied for the Doherty structure [9, 10]. In this paper, the detailed circuit design of the highly efficient and linear DPA is

Manuscript September 17, 2014 ; Revised October 29, 2014 ; Accepted November 5, 2014. (ID No. 20140917-038J)

Department of Electrical Engineering, Pohang University of Science and Technology (POSTECH), Pohang, Korea.

*Corresponding Author: Bumman Kim (e-mail: bmkim@postech.ac.kr)

This is an Open-Access article distributed under the terms of the Creative Commons Attribution Non-Commercial License (<http://creativecommons.org/licenses/by-nc/3.0>) which permits unrestricted non-commercial use, distribution, and reproduction in any medium, provided the original work is properly cited.

© Copyright The Korean Institute of Electromagnetic Engineering and Science. All Rights Reserved.

presented in Section II, followed by the simulation and experimental results of the PA in Section III.

II. HIGHLY EFFICIENT AND LINEAR ASYMMETRIC DOHERTY POWER AMPLIFIER

For the base station application, the DPA is usually designed in a hybrid configuration consisting of discrete power cells and distributed passive elements. The hybrid configuration is not an appropriate structure for a small-cell base station because it occupies a large area. Selection is also limited for the device sizes of the carrier and peaking PAs due to device availability.

However, no limitation exists for the MMIC with respect to selection of the sizes of the carrier and peaking PAs. We obtained a high efficiency for amplification of the LTE signal with 7.2-dB PAPR by calculating the efficiency for an ideal asymmetric DPA with different cell size ratio of the carrier and peaking PAs from 1:0.8 to 1:2.0. From the ideal simulation result, we find that a 1:1.4 cell size ratio provides the highest efficiency, which is a 1.2% higher average efficiency than a symmetric structure, as shown in Table 1. Therefore, we design the DPA with 1:1.4 cell size ratio for a good efficiency performance.

Fig. 1 shows the input voltage waveform of the PA with and without the second harmonic short circuit at the input.

Due to the nonlinear input capacitor [11], the second harmonic of the input voltage is out-of-phase with the fundamental component. The out-of-phase second harmonic component increases the conduction angle of the input voltage waveform, as shown in Fig. 1. The increased conduction angle results in a larger DC component for the current waveform, which degrades

Table 1. The efficiency of the asymmetric Doherty power amplifier (DPA) for the LTE signal according to the size ratio of the carrier and peaking PAs

| Size ratio | 1:1.0 | 1:1.2 | 1:1.4 | 1:1.6 | 1:1.8 | 1:2.0 |
|----------------|-------|-------|-------|-------|-------|-------|
| Efficiency (%) | 61.1 | 62.0 | 62.3 | 62.1 | 61.5 | 60.7 |

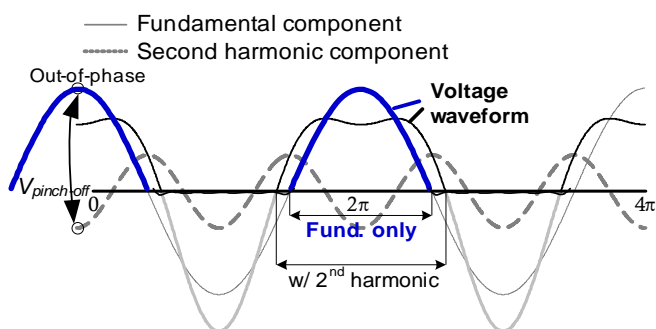

Fig. 1. Input voltage waveform of the Doherty power amplifier with and without the second harmonic short circuit.

the efficiency of the PA. The efficiency is enhanced by inserting the second harmonic short circuit at the input of the carrier PA. However, in the case of the peaking PA, the matching concept should be different. It has a lower output power due to the class C-bias and this lower output power leads to the improper load modulation of the DPA. Therefore, the second harmonic short circuit is not inserted at the input of peaking PA to get the additional output power needed for proper load modulation.

The DPD technique is widely used the base station to linearize the PA. However, the DPD circuit board consumes too much power to be useful for the small-cell base station. Therefore, one solution could be a light PD system that consumes less DC power. However, the linearization capability of the light PD system is limited and the DPA should have high linearity. The linearity of the DPA can be improved by cancelling out the IM3s of the carrier and peaking the amplifier at the output combining point. The gain compression cha-

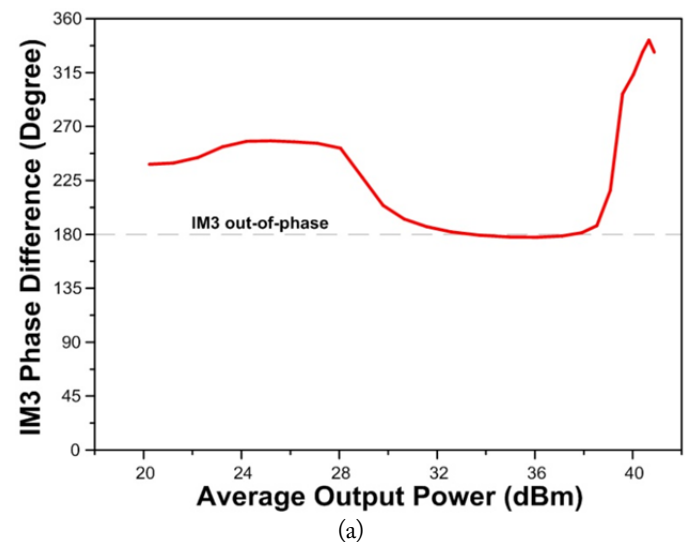
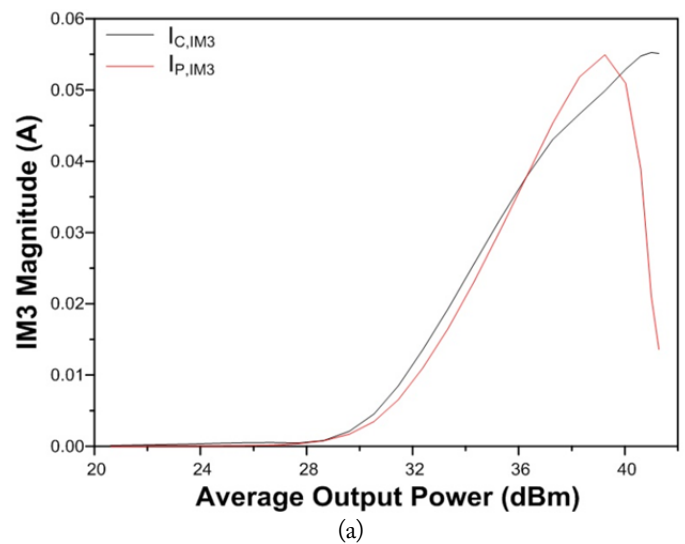

Fig. 2. Simulated IM3 magnitude (a) and IM3 phase differences (b) of the carrier and peaking PAs.

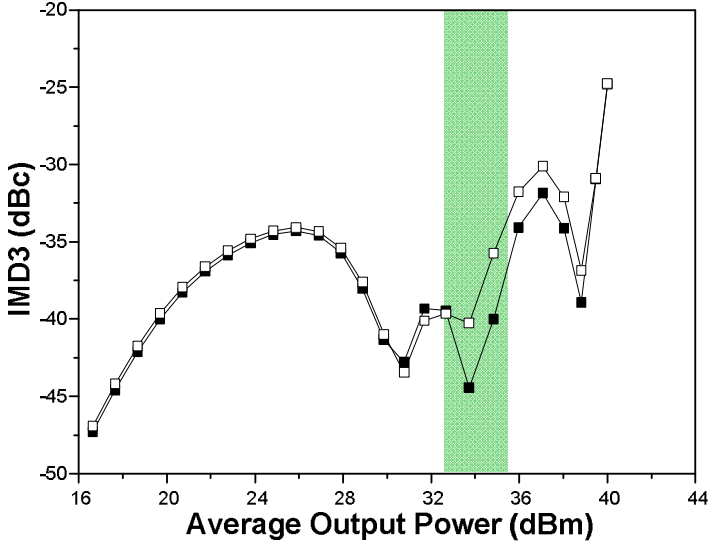

Fig. 3. Simulated two-tone IMD3 curves of the proposed DPA.

characteristics of a class AB carrier PA and the gain expansion of the class C peaking PA make it possible to cancel them. When the IM3 characteristics of the amplifiers are perfectly satisfied with the Eqs. (1) and (2), the IM3s are cancelled out maximally at the output combining point of the Doherty topology,

$$|I_{C,IM3}| = |I_{P,IM3}| \quad (1)$$

$$\angle I_{C,IM3} = \angle I_{P,IM3} \pm \pi \quad (2)$$

Fig. 2 shows the magnitude and phase differences between $I_{C,IM3}$ and $I_{P,IM3}$ according to the output power. The simulation result shows that the Eqs. (1) and (2) are satisfied near 34 dBm output power region. Fig. 3 shows the two-tone IMD 3 curves of the proposed DPA. Employing the IM3 cancellation method gives an IMD3 under 35 dBc near the output power of 34 dBm.

III. SIMULATED AND EXPERIMENTAL RESULTS

The design concept is validated by designing a highly linear 2-stage DPA using Agilent Advanced Design System. An overall schematic of the linear asymmetric 2-stage DPA is shown in Fig. 4. The total gate width of the drive PA, carrier PA, and peaking PA are $560 \mu\text{m}$, $2,080 \mu\text{m}$, and $2,912 \mu\text{m}$, respectively. The second harmonic short circuit and merged inductor are adopted for a high efficiency and small size. The IM3 cancellation method is applied for a high linearity. For the simulation, the drain bias voltages of the drive PA, carrier PA, and peaking PA are set to 20 V, 28 V, and 28 V, respectively. The quiescent current of the drive PA and carrier PA are set to the class-AB bias with 28 mA and 160 mA, respectively. Fig. 5 shows the simulated performances of the 2-stage DPA for a 2.14-GHz CW signal. The simulated drain efficiency and gain at 7.2 dB back-off power level are more than 40.0% and 32.5 dB, respectively, and the peak output power is over 41 dBm.

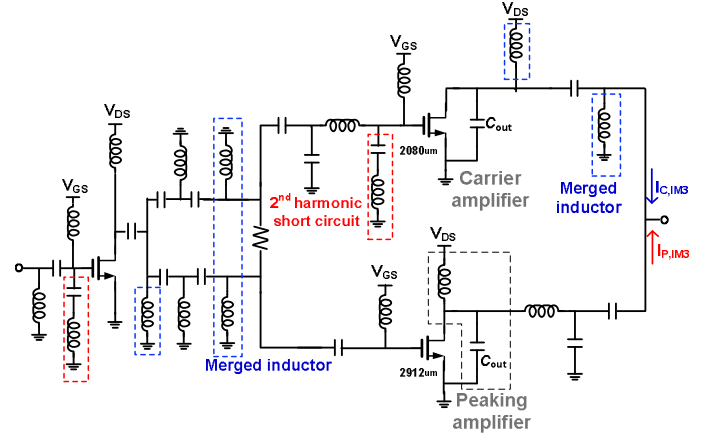

Fig. 4. Schematic of the proposed 2-stage Doherty power amplifier.

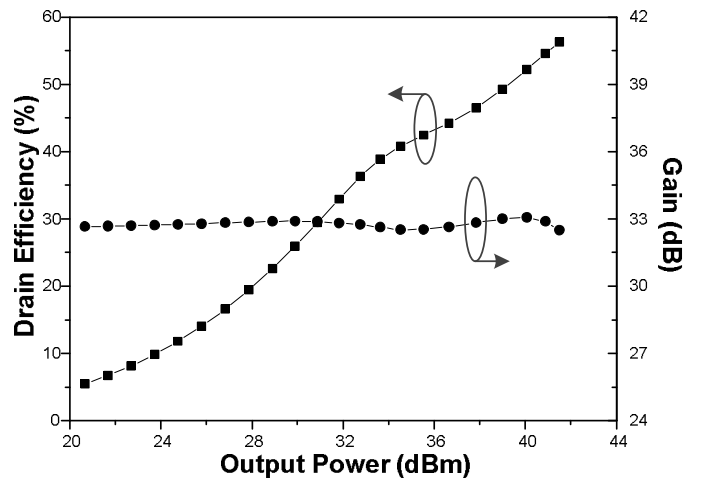

Fig. 5. Simulated efficiency and gain of the proposed Doherty power amplifier.

The proposed asymmetric 2-stage DPA is validated by realizing the PA using TriQuint 3MI 0.25- μm GaN-HEMT MMIC process. The integrated circuit size, except for the RF choke inductor, is only $3.5 \text{ mm} \times 2.1 \text{ mm}$ as shown in Fig. 6.

For the experiment, drain bias voltages of the drive PA,

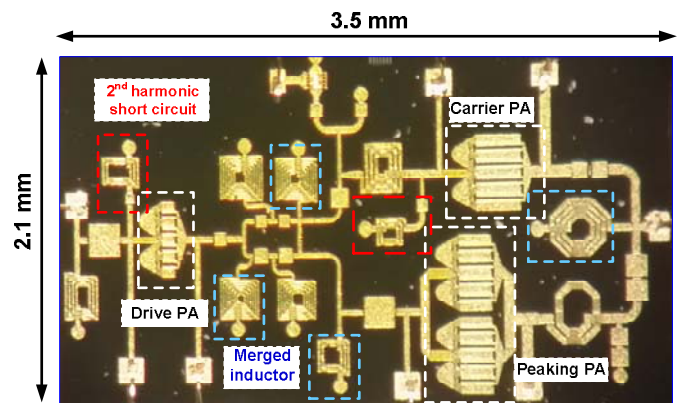

Fig. 6. Photograph of a fabricated chip of the proposed 2-stage Doherty power amplifier (DPA).

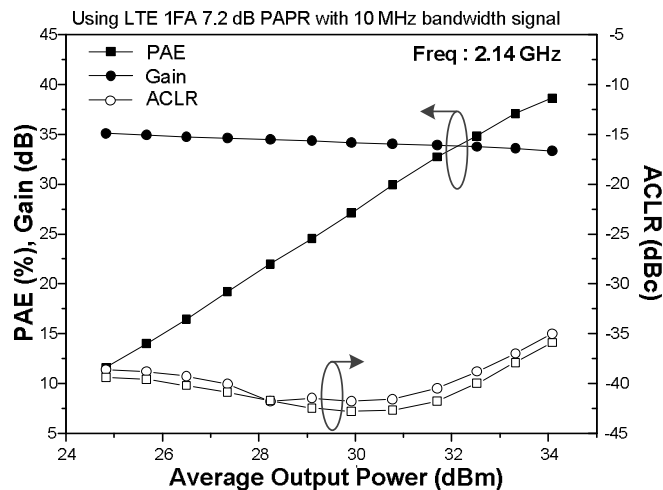

Fig. 7. Measured power-added efficiency, gain, and adjacent channel leakage ratio (ACLR) of the fabricated power amplifier at 2.14 GHz LTE signal with 7.2 dB peak-to-average power ratio (PAPR). PAE = power-added efficiency.

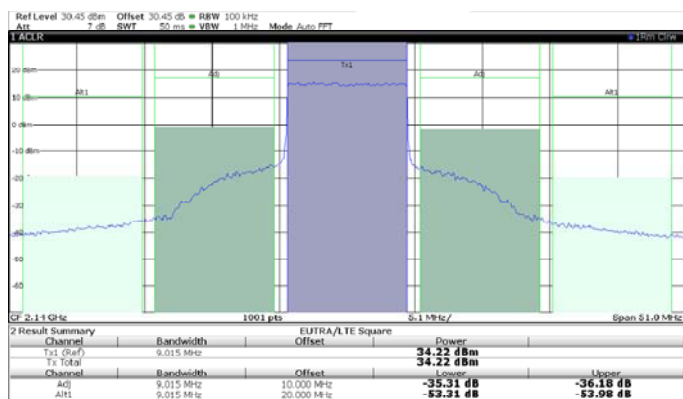

Fig. 8. The measured output power spectra of the proposed power amplifier at 34.2 dBm.

carrier PA, and peaking PA are set to 20 V, 28 V, and 28 V, respectively. The quiescent currents of the drive PA and carrier PA are 28 mA and 160 mA, respectively, class-AB biases. The high efficiency and linearity of the asymmetric DPA for the modulated signal is validated by testing the PA using an LTE signal with 10-MHz bandwidth and 7.2-dB PAPR at 2.14 GHz. Fig. 7 shows the measured efficiency, gain, and adjacent channel leakage ratio (ACLR) characteristics. The implemented 2-stage DPA delivers the power-added efficiency (PAE) of 38.6%, a gain of 33.4 dB, and ACLR of -35.3 dBc at an average power of 34.2 dBm. Fig. 8 shows the measured output spectra of the proposed DPA at an average output power of 34.2 dBm. From the output spectra, we can recognize the high linear characteristic of the proposed DPA. For comparison, the performances of the recently reported MMIC PAs are summarized in Table 2. The linearity and efficiency of the proposed DPA is favorable among the reported PAs for small-cell base station systems.

Table 2. Performance comparison of recently reported MMIC DPA

| | Lee et al. [5] | Kim et al. [6] | Kang et al. [12] | This work |
|-----------------|-------------------|-------------------|---------------------|------------------|
| Freq (GHz) | 2.14 | 2.14 | 1.6–2.1 | 2.14 |
| P_{out} (dBm) | 35.3 | 33.2 | 27.5 | 34.2 |
| Gain (dB) | 19.7 | 15.7 | 27–32 | 33.4 |
| PAE (%) | 39.6 | 50.4 | 30–36 | 38.6 |
| ACLR (dBc) | -25.3 | -34.7 | -31.0 | -35.3 |
| Technology | GaN | GaN | GaAs | GaN |
| | HEMT | HEMT | HBT | HEMT |
| Chip-size (mm) | 2.7×2.5 | 3.3×2.6 | 1.4×1.4 | 3.5×2.1 |

MMIC = monolithic microwave integrated circuit, DPA = Doherty power amplifier, PAE = power-added efficiency, ACLR = adjacent channel leakage ratio.

IV. CONCLUSION

An asymmetric DPA based on GaN HEMT MMIC process is designed and fabricated for a small-cell base stations. The highest efficiency for 7.2-dB PAPR LTE signal is obtained with the asymmetric DPA which has 1:1.4 cell size ratio for the carrier and peaking PAs is designed. A higher efficiency is obtained by inserting a second harmonic control circuit at the carrier PA. The operation is highly linear when the IM3 cancellation method is applied. With this design concept, the asymmetric DPA is implemented using the TriQuint 3MI 0.25- μ m GaN-HEMT MMIC process. At 2.14 GHz, the implemented PA delivers a PAE of 38.6%, a gain of 33.4 dB, and an ACLR of -35.3 dBc at an average power of 34.2 dBm for LTE signal with a 7.2-dB PAPR.

The authors would like to thank Rohde & Schwarz for providing the signal generator and spectrum analyzer used in this study.

REFERENCES

- [1] L. Kahn, "Single-sided transmission by envelope elimination and restoration," *Proceedings of The Institute of Radio Engineers*, vol. 40, no. 7, pp. 803–806, 1952.
- [2] F. H. Raab, B. E. Sigmon, R. G. Myers, and R. M. Jackson, "L-band transmitter using Kahn EER technique," *IEEE Transactions on Microwave Theory and Techniques*, vol. 46, no. 12, pp. 2220–2225, Dec. 1998.
- [3] F. Wang, D. F. Kimball, J. D. Popp, A. H. Yang, D. Y. Lie, P. M. Asbeck, and L. E. Larson, "An improved power-added efficiency 19-dBm hybrid envelope elimination and restoration power amplifier for 802.11g WLAN applications," *IEEE Transactions on Microwave Theory and Te-*

- chniques, vol. 54, no. 12, pp. 4086–4099, Dec. 2006.
- [4] Y. Yang, J. Yi, Y. Y. Woo, and B. Kim, "Optimum design for linearity and efficiency of microwave Doherty amplifier using a new load matching technique," *Microwave Journal*, vol. 44, no. 12, pp. 20–36, Dec. 2001.
- [5] J. Lee, D. H. Lee, and S. Hong, "A Doherty power amplifier with a GaN MMIC for femtocell base stations," *IEEE Microwave and Wireless Components Letters*, vol. 24, no. 3, pp. 194–196, Mar. 2014.
- [6] C. H. Kim, S. Jee, G. D. Jo, K. Lee, and B. Kim, "A 2.14-GHz GaN MMIC Doherty power amplifier for small-cell base stations," *IEEE Microwave and Wireless Components Letters*, vol. 24, no. 4, pp. 263–265, Apr. 2014.
- [7] J. Kim, B. Fehri, S. Boumaiza, and J. Wood, "Power efficiency and linearity enhancement using optimized asymmetrical Doherty power amplifiers," *IEEE Transactions on Microwave Theory and Techniques*, vol. 59, no. 2, pp. 425–434, Feb. 2011.
- [8] D. Gustafsson, J. C. Cahuana, D. Kuylenstierna, I. Angelov, N. Rorsman, and C. Fager, "A wideband and compact GaN MMIC Doherty amplifier for microwave link applications," *IEEE Transactions on Microwave Theory and Techniques*, vol. 61, no. 2, pp. 922–930, Feb. 2013.
- [9] I. Kim, J. Cha, S. Hong, J. Kim, Y. Y. Woo, C. S. Park, and B. Kim, "Highly linear three-way Doherty amplifier with uneven power drive for repeater system," *IEEE Microwave and Wireless Components Letters*, vol. 16, no. 4, pp. 176–178, Apr. 2006.
- [10] Y. Cho, D. Kang, J. Kim, K. Moon, B. Park, and B. Kim, "Linear Doherty power amplifier with an enhanced back-off efficiency mode for handset applications," *IEEE Transactions on Microwave Theory Techniques*, vol. 62, no. 3, pp. 567–578, Mar. 2014.
- [11] J. Moon, J. Kim, and B. Kim, "Investigation of a class-J power amplifier with a nonlinear C_{out} for optimized operation," *IEEE Transactions on Microwave Theory Techniques*, vol. 58, no. 11, pp. 2800–2811, Nov. 2010.
- [12] D. Kang, D. Kim, Y. Cho, B. Park, J. Kim, and B. Kim, "Design of bandwidth-enhanced Doherty power amplifiers for handset applications," *IEEE Transactions on Microwave Theory Techniques*, vol. 59, no. 12, pp. 3474–3483, Dec. 2011.

Seunghoon Jee



received the B.S. degree in electronic and electrical engineering from Kyungpook National University, Daegu, Korea, in 2009 and is currently working toward the Ph.D. degree at the Pohang University of Science and Technology (POSTECH), Pohang, Korea. His current research interests include highly linear and efficient RF PA design and broadband RF PA design.

Seokhyeon Kim



received the B.S. degree in electrical engineering from the Pohang University of Science and Technology (POSTECH), Pohang, Korea, in 2011 and is currently working toward the Ph.D. degree in POSTECH. His current research interests include highly linear and efficient RF power-amplifier design.

Juyeon Lee



received the B.S. degree in electrical engineering from the Pohang University of Science and Technology (POSTECH), Pohang, Korea, in 2011 and is currently working toward the Ph.D. degree in electrical engineering from POSTECH. His current research interests include highly efficient RF power amplifier design.

Yunsik Park



received the B.S. degree in electrical engineering from the Pohang University of Science and Technology (POSTECH), Pohang, Korea, in 2012 and is currently working toward the Ph.D. degree in IT Convergence Engineering at POSTECH. His current research interests include highly efficient power amplifier for wireless communications, with a special focus on Doherty power amplifier.

Bumman Kim



(M78–SM97–F07) received the Ph.D. degree in electrical engineering from Carnegie Mellon University, Pittsburgh, PA, in 1979. He joined the Central Research Laboratories, Texas Instruments Incorporated, where he was involved in development of GaAs power field-effect transistors (FETs) and monolithic microwave integrated circuits (MMICs). He has developed a large-signal model of a power field-effect

transistor (FET), dual-gate FETs for gain control, high-power distributed amplifiers, and various millimeter-wave monolithic microwave integrated circuits (MMICs). In 1989, he joined the Pohang University of Science and Technology (POSTECH), Pohang, Korea, where he is currently a POSTECH Fellow and a Namko Professor with the Department of Electrical Engineering and Division of Information Technology Convergence Engineering (ITCE). He is involved in device and circuit technology for RF integrated circuits (RFICs) and PAs. He has authored over 300 technical papers. Prof. Kim is a member of the Korean Academy of Science and Technology and the National Academy of Engineering of Korea. He was an associate editor for the IEEE Transactions on Microwave Theory and Techniques, a Distinguished Lecturer of the IEEE Microwave Theory and Techniques Society (IEEE MTT-S), and an IEEE MTT-S Administrative Committee (AdCom) member.