

Design and Implementation of Fully Automated Solar Powered Irrigation System

Mohammad Fawzi Al Ajlouni¹, Essam Ali Al-Nuaimy², Salman Abdul-Rassak Sultan³, Ali Hammod

AbdulHussein Twaij⁴, Al Smadi Takialddin⁵

¹Civil Engineering Department, University of Jerash, Amman-Irbid Highway, Jerash, Jordan

m.ajlouni@jpu.edu.jo

²College of Engineering University of Jerash, Amman-Irbid Highway, Jerash, Jordan

³Independent Researcher, 397 Gower Road, Killay, Swansea, SA2 7AH, UK

⁴College of Engineering, University of Kufa, Iraq

⁵College of Engineering, Jerash University, Jerash, Jordan.

dsmaditakialddin@gmail.com

*Corresponding author. Email: m.ajlouni@jpu.edu.jo

Abstract

This paper presents a fully automated stand-alone irrigation system with GSM (Global System for Mobile Communication) module. Solar energy is utilized to power the system and it is aimed to conserve water by reducing water losses. The system is based on a DC water pump that draws energy from solar panels along with automated water flow control using a moisture sensor. It is also fitted with alert and protection system that consists of an ultrasonic sensor and GSM messages sender that transmits signals showing the levels of the water in the reservoir and the battery charge. The control system is designed to stop the water pump from pumping water either when the battery level drops to equal or less than 10% of its full charge, or when the water level becomes less than 10 cm high in the reservoir. The experimental results revealed that the system is appropriate to use in remote areas with water scarcity and away from the national grid.

Keywords:

Soil Moisture Sensor, Automated Irrigation, Water Pump, Arduino Uno Microcontroller, Ultrasonic Sensor, GSM SIM900 Module.

1. Introduction

Water is essential for every form of life, for all aspects of socio-economic development, and for the maintenance of healthy ecosystems. It is the

only material that can be found on planet earth in three statuses under normal conditions (liquid, solid and gas). While there are sufficient freshwater resources at the global level to enable continuous agricultural and industrial development, the long-term sustainable use of water resources is of growing concern for international bodies. This is particularly the case when considering the intrinsic disparity in water quality and availability across regions. On average, agriculture accounts for 70 per cent of global freshwater withdrawals [1].

To solve the problem of freshwater scarcity in many regions, scientists have developed ways of intelligent irrigation systems that minimize and properly manage the use of fresh water. Such systems are convenient to use in remote regions [2]-[15], which provide important information and feedback on the state of the irrigation process.

The cloud system works wirelessly in two modes: either in closed loop control mode, when the microcontroller controls the opening and closing of the solenoid valve to the required amount of water for crops based on the average soil moisture, or the agronomist uses remote cloud data to start the channel by entering a specific

values. Compound. The one at the bottom of the duct is for turning the solenoid valve on and off. Sensor data is collected using wireless communication to avoid running signal wires and cables infield.

In remote regions, particularly in areas that are not connected to the national grid and where the normal supply of liquid fuels and its maintenance is difficult to sustain, there is a need for an alternative source of energy. The present irrigation system is an attempt to tackle the issues of the energy supply and dearth of the freshwater. Solar PVs are used as a source of energy that generates electricity required to powering the system. The lack of freshwater abundance management is addressed by providing the right amount of moisture at the roots of the crops, thus avoiding wasting water. This is achieved by using a soil moisture sensor. The system is fitted with alerting GSM module that transmits SMS (Short Message Service) thus alarming about the water level in the reservoir and the battery charges for control purposes.

2. COMPONENTS OF THE IRRIGATION SYSTEM

Solar power module

Three 112mm x 91mm 1.5 watts 6 volts polycrystalline solar cell panel modules have been used in this study to convert solar radiation into electric current.

Solar charge controller

A CML 10 solar charge controller used in this study was connected between the PV generator, a 12V battery and the load. It is the most important component in the PV standalone systems with battery storage. The charge controller regulates the flow of electricity from the PV modules to both the battery and the load. The controller keeps the battery fully charged without overcharging it. When the load is drawing power, the controller allows charge to flow from the modules into the battery, the load, or both. When the controller senses that the battery is fully charged, it stops the flow of charge from the modules and at the same time it prevents reverse current flow during periods of no sunshine.

Direct current battery

A storage battery is an excellent system for supplying electricity when and where is needed during days of overcast when solar power is not available. The battery used in this study is GP 1272 12V DC type with rated capacity of 7.2 AH @ 20-hour rate.

Buck converter module

The purpose of using the buck converter module is to step down the source voltage from 12V to 5V to be compatible with the Arduino Uno microcontroller and the GSM module. The buck converter used in this study is LM2596 module. The converter is capable of driving a load up to 3A with high efficiency, which can work with Arduino Uno and other basic modules. A heat sink was added to cool down the heat generated by the converter.

Direct current water pump

A Mini 6V-12V DC Brushless Small Water Pump Submersible Motor Pump 1.8M 230L/H is used in this study. The operating voltage: 6-12V (voltage more than 12V is not advised), current 310mA at 12Vdc, Max static head 1.8 meters, Max horizontal flow 230L / H. The minimum size of the pump is 4.36cm×2.88cm×2.8cm.

Arduino Uno microcontroller

In this study an Arduino Uno microcontroller used to coordinate all the activities of the irrigation system. The Arduino Uno is an open-source microcontroller board based on the Microchip ATmega328P microcontroller. The board is equipped with sets of digital and analogue input/output (I/O) pins that may be interfaced to various expansion boards (shields) and other circuits. The board has 14 digital I/O pins (six capable of PWM output), 6 analogue I/O pins, and is programmable with the Arduino IDE (Integrated Development Environment), using the Arduino script programming language and uploaded to the microcontroller via a type B USB cable.

Keyes relay module

The new KEYES 5V Relay Module is perfectly made for Arduino applications used in this study. It has three pins, the VCC, GND and Signal. It is a switch used to convert the circuit from open mode into a close mode on receiving signal from the Arduino. It has a red LED that turns on every occasion the coil is energized, or the sign pin has a high input.

Moisture sensor

A Soil Moisture Sensor YL-69 is used to measures the amount of water in the soil. The sensor converts the soil moisture content into electronic signal and sends it to the microcontroller. The microcontroller then operates the water pump according to the amount of moisture (percentage of water) in the soil.

Ultrasonic sensor

The HC-SR04 is a high-frequency ultrasonic sensor that sends sound waves and receives echo from which the water level can be determined. It is a kind of eco sounder that offers high precision and stable readings from 2 cm to 400cm.

GSM module

This is a specialized modem that accommodates a SIM card just like a mobile phone. It operates at frequencies of 850/900/1800/1900MHz and can be used to send and receive messages. To perform these tasks, a GSM modem must support an “extended AT command set” for sending/receiving SMS messages.

System design

Solar energy is the most abundant source of energy in the world. Solar energy is not only an answer to the current energy crisis but also an environmentally friendly form of energy. PV Generation is an efficient approach to using solar energy. One of the applications of this technology is in irrigation systems for agriculture. *integrated irrigation system* can be a

A suitable alternative for farmers in this current state of energy crisis. This is a green energy production method that provides free energy after system development.

Power Supply

The moisture sensor is used to determine the level of moisture in the soil. The microcontroller reads this level of humidity. If the value is higher than the present value, the GSM module is ready to send an SMS to the recipient.

The temperature and humidity sensor are used to determine if it is too hot for the plant or the humidity is too high to handle. This is read by the ATmega328p Arduino Uno chip. This reading will be used to determine if the solenoid in the system should be turned on or off. Pump 5V electric motor, L293D (IC1) motor, drive motor IC to start the water pump. The Arduino board can be powered by a 5V to 9V power supply, which can be either a battery, an auxiliary converter, or a solar panel. The water pump is operated separately from 5V to a separate 9V [5].

And using the unit conversion intensity, where this unit consists of transistors (BC109) that act as a switch, relays and a DC motor. Moisture sensor works using the principle of relationship between conductivity and moisture content of a medium. Specifications Operating voltage -5V analog type .Relay work for different test conditions Shown in Table 1

Table 1. Operation of relay for various soil moisture conditions.

S/ N	Voltage range	Soil moisture		Amplifier output	Relay reference pin	Relay 'NO' contact	Water pump operation
		condition	Q				
1	> 5V	Excess wet	0	1	1	open	OFF
	<5V&	Optimally Wet	0	1	1	open	OFF
2	> 3V	Optimally Dry	1	0	0	closed	ON
3	< 3V	Dry	1	0	0	closed	ON

A sensor is a device that measures a physical quantity and then converts it into a signal that an observer can read. Three copper conductors are used to form a sensor probe connected to a 5V DC supply that is connected to the microcontroller. The conductors are separated from each other, so that when they are introduced into the soil, there will be a change in the voltage signal to the microcontroller due to the state of soil moisture. When water fills the gap, resistance arises between the probes, and a voltage signal is transmitted to the microcontroller.

The circuit diagram of the proposed irrigation system is shown in (Fig. 1).

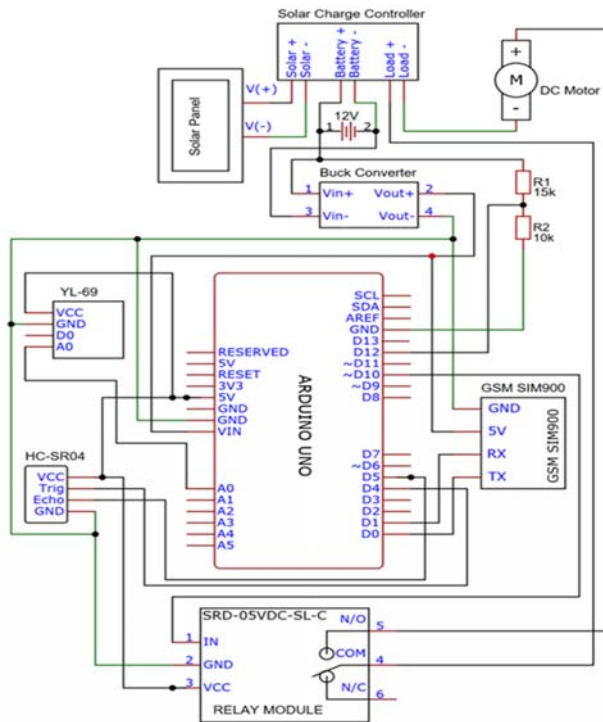

Fig. 1. The circuit diagram of the fully integrated irrigation system.

The Arduino microcontroller is used to collect feedback signals (Analog signals) from the moisture sensors, ultrasonic sensor, and the voltage divider to start-up the water pump.

The moisture sensor measures the moisture of the soil continuously and sending the readings to the Arduino to decide whether or not the water pump should start operating. The moisture sensor has two output pins A_0 and D_0 that display the magnitude of the soil humidity in different signal forms, analogue and digital. Pins A_0 sends the information to the Arduino in an analogue form, while D_0 in digital format. In this project the analogue mode was chosen for interfacing, as a continuous monitoring of the humidity values is required. Therefore, A_0 is connected to the analog input A_0 pin of the Arduino for feeding back humidity values. If the digital format is used, then any sudden change in values will cause the Arduino to start-up the water pump and therefore

it is preferable to use the analog mode to avoid unnecessary operation of the water pump.

The ultrasonic sensor is installed on the top of the water tank to measure the level of the water inside by sending and receiving sound waves. The ultrasonic sensor has four pins (VCC, GND, ECHO, and TRIG). The VCC and GND pins of the sensor are connected to the VCC and GND pins of the Arduino through Relay Module respectively. The TRIG and ECHO pins of the ultrasonic sensor are connected to the digital inputs 4 and 5 of the Arduino respectively. The relay has three pins VCC, GND, and SIG that are connected to the VCC, GND, and the digital input 10 of Arduino respectively. The relay is used in normally open circuit mode instead of a closed circuit mode to connect the water pump to the power supply as the water pump needs to switch on only occasionally. The GSM module is connected to the Arduino vice versa, i.e., the TX and RX pins of the GSM are connected to the RX and TX pins of the Arduino respectively

3. System operation sequence

The moisture sensor can be regarded as the hub of operation as it triggers the operation of the system. Two predetermined values of moisture level are assigned into the program of Arduino, a low and a high one (threshold values). The selection of the predetermined values depends on knowledge from agriculture background as to what the most suitable values that provides the crops with the necessary amount of moisture. The sensor continuously measures the moisture level of the soil and sends readings to the Arduino, which in turn compare them with the predetermined values. When the measured readings of the soil moisture becomes below or equal to the low predetermined value stored within the program, the Arduino sends a signal to the relay to connect the normally open contact (NO) and thus closing the circuit and turning the water pump on. During the irrigation process, the moisture sensor continuously sends reading to the Arduino and once the moisture level of the sensor reaches the high

predetermined value, the Arduino will signal the relay to change its status and thus switching off the water pump.

Alert and protection system

Finally, the alert and protection system of the project consist of two parts. The part 1 is related to the ultrasonic sensor to alert that water level in the reservoir is low. When the water level reaches 10 cm, the Arduino switches off the water pump and send a message “tank about to empty” to a mobile number such as (+962789516132) via the GSM module as shown in (Fig. 2).

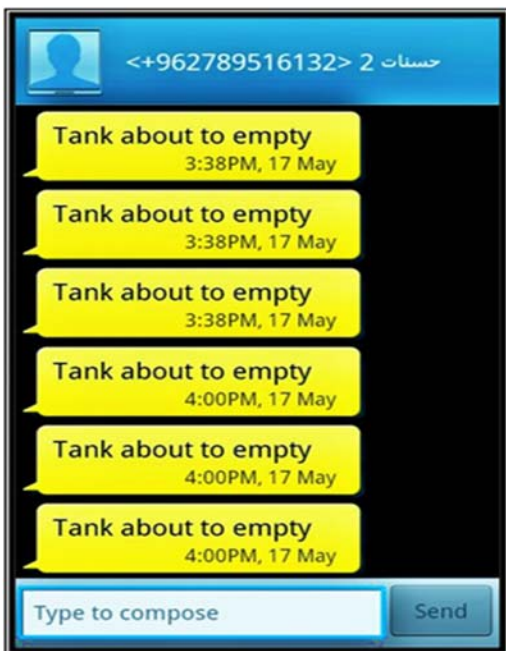

Fig. 2. Alert message showing empty tank.

The purpose of this protection system is to switch off the water pump from operating as continuous pumping with no water flowing increases the pump winding temperature and destroys the water pump.

The part 2 of the protection system is accomplished by inserting a voltage divider between the positive terminal of the battery and the digital pin 12 of the Arduino as shown in (Fig. 1). The purpose of using the voltage divider is to reduce the voltage level from 12 to 5 volts to be compatible with the Arduino high state

level. When the battery level reaches 10% of its value, the Arduino sends a signal to switch off the water pump and sends a message “battery about to empty” to a mobile number (+962789516132) via the GSM module as shown in (Fig. 3).



Fig. 3. Alert message showing empty battery.

The purpose of this protection system is protecting the battery from over-discharging, because if the load is still connected and the level of the battery decrease continuously, this leads to the damage of the battery.

System flow chart

The flow chart of the developed algorithm is shown in (Fig. 4). The system automatically tests the level of humidity, the water level within the tank and the voltage level of the battery. The Arduino then decides to turn on or off the water pump without human intervention via GSM. Farmers receive SMS about the condition of the water level inside the tank and the battery voltage level.

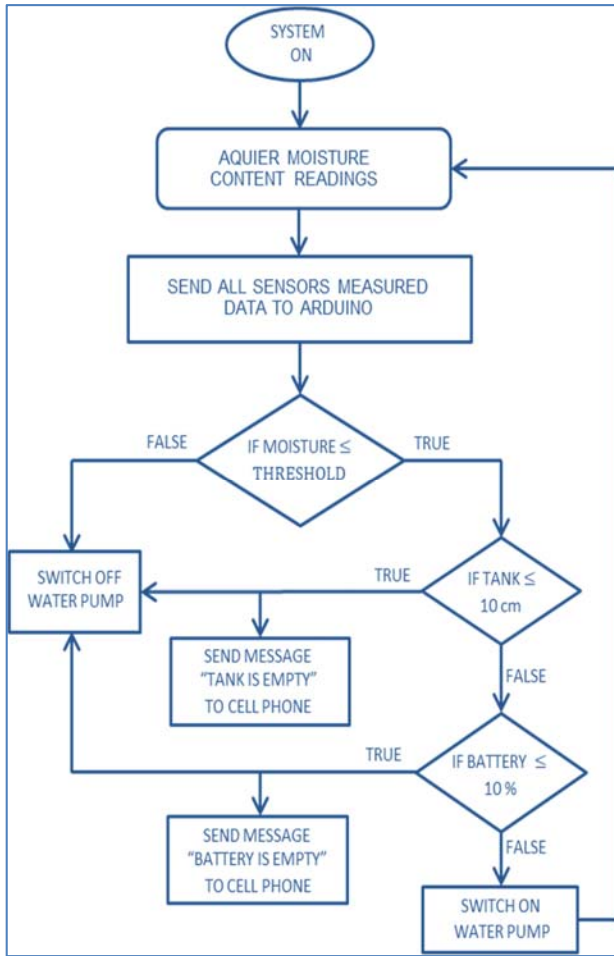

Fig. 4. Flow chart of the system.

4. RESULTS AND DISCUSSION

The assembly of the Arduino based automatic soil moisture monitoring system shown in (Fig. 5)



Fig. 5. The laboratory-developed prototype of fully automated irrigation system.

was implemented and tested successfully in the field. Experimental tests have shown that the system operates as expected, with the moisture sensor successfully controlling the water pump during the irrigation process. The alarm and safety system operated effectively by sending warnings about the water level inside the tank, and the voltage level of the battery charging as shown in table2 and Volume of Water Consumed, Load Current Drawn and Time

Table 2. Battery charging operation.

Time of test	Battery voltage (Volts)	PV voltage (volts)	Charging current
8	12,4	17,5	2,97
8:30	12,3	20	2,1
9:00	13,25	20,13	1,4
9:30	13,56	17,51	1,7
10:00	13,75	18,5	1,9
10:30	14,1	19,2	0,8
11	14,12	19,2	0,78

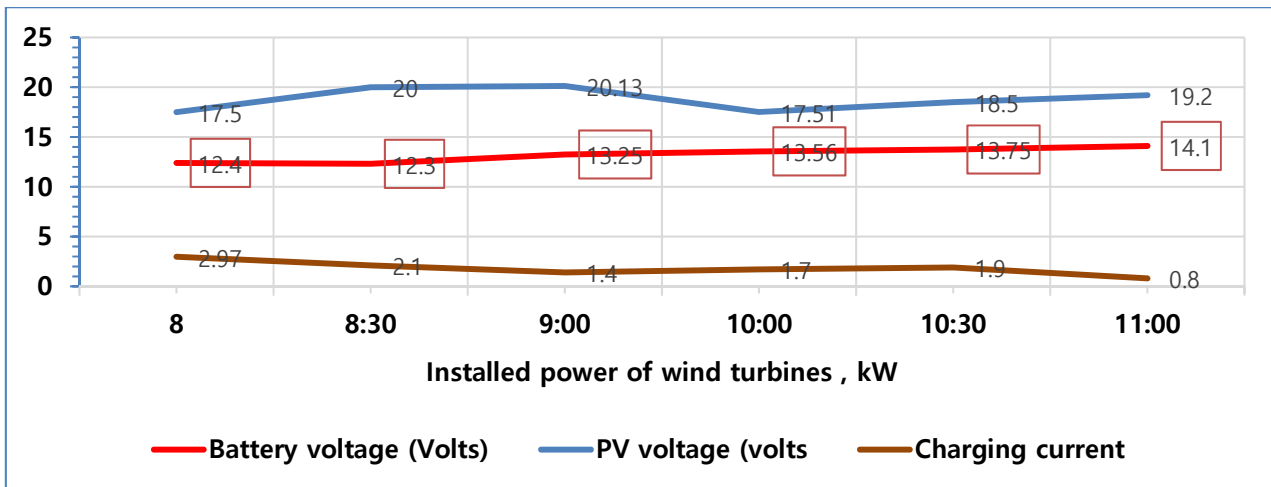

Fig 6. Battery charging operation

5. Control analysis of soil condition

The control/sensor circuit is powered by a 12V battery which is connected via a voltage regulator to a 5V output. The moisture sensor used is of the resistive type. It directly depends on the resistance of the soil by the LED indicator, the signal changes from red to yellow to keep the water resistance low. When the soil is supplied with 100 to 125 liters of water, the resistance of the soil begins to

decrease at a lesser rate. It becomes saturated with water so adding more water has little effect on soil resistance . Sensor calibration was established identifying three states. Soggy, wet and dry.

When the dry state was reached, the control unit (microcontroller) ran the water pump through the relay circuit. Showing the three states using three different LED lights. The alarm system is also triggered if the pump is running. Here the control circuit and sensor circuit are shown in Table 3 and Figure 7. Soil Condition Control Analysis

Soil content	water LED	Light sensor	Alarm	Moisture sensor
Red	0	off	ON	ON
Yellow	50	off	ON	ON
Yellow	75	off	ON	ON
Gren	100	off	ON	ON
White	120	off	OF	OF
white	125	off	OF	OF

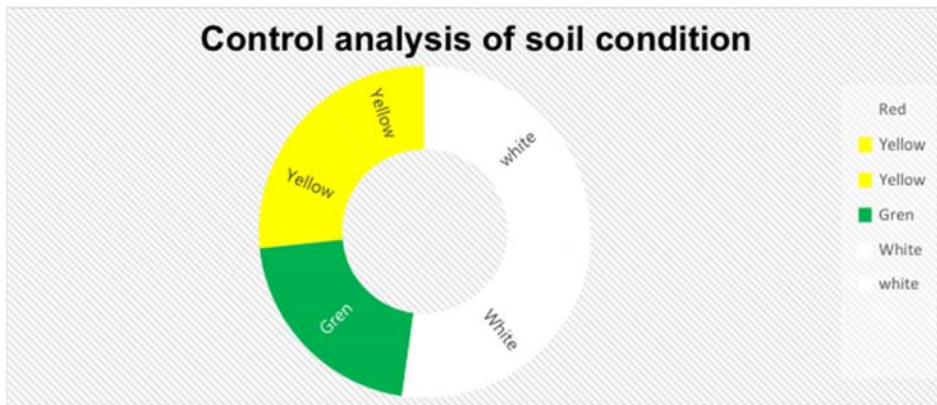

fig 7 Control analysis of soil condition

6. Conclusion

The proposed irrigation system offers various benefits. The system optimizes the usage of water reducing water wastage and reduces human intervention. Also, any excess energy generated by the solar panels can be sold to the government by connecting the proposed system with the national grid, which can be regarded an additional source of income to farmers. The proposed system of irrigation is environmentally friendly and sustainable, as it does not use fossil fuels thus limiting emissions of greenhouse gases. The various elements of the system are not costly and thus affordable in the long terms. It is very suitable to use in remote areas and arid zones as it is independent of the national power and is water efficient. The purpose of the research is to get positive results to get more efficient in the field Inexpensive irrigation system and a product that can help Farmers to carry out their cultivation and increase agricultural production by using some modern technological applications

KNOWLEDGEMENTS

This Work was supported by the Deanship of Scientific Research the author Jerash University, our thanks to reviewers for their valuable suggestions to enhance the quality of our article.” This work has been carried out during sabbatical leave granted to the author the authors wish to express their profound gratitude the Ministry of Higher Education and Scientific Research in Iraq

Conflict of interests

The authors declare that there is no competing interest.

REFERENCES

- [1] Food and Agriculture Organization of the United Nations (2017). Water for sustainable food and agriculture. Retrieved from <http://www.fao.org/3/a-i7959e.pdf>.
- [2] Das, S., Pal, B., Das, P., Sasmal, M. & Ghosh, P. (2017). Design and development of Arduino based automatic soil moisture monitoring system for optimum use of water in agricultural fields. *International Journal of Engineering Research and Science*, 3(5), 15-19.

- [3] Lwin, M. M., Win, S. & San, Z. C. (2018). Automatic pump controller for solar photovoltaic irrigation system. *International Journal of Trend in Scientific Research and Development*, 2(5), 2362-2367.
- [4] Mahatol, B., Yadav, A. K., Magar, S. T. & Janardha, K. (2018). Solar based automatic irrigation using soil moisture sensor. *International Research Journal of Engineering and Technology*, 5(5), 1781-1784.
- [5] Kapse, N., Wadibhasme, H., Sonkure, N., Vikhar, R. & Pandhare, A. (2018). GSM module operated solar powered water pump. *International Journal of New Technology and Research*, 4(3), 154-156.
- [6] Kumar, S., Sethuraman, C. & Srinivas, K. (2017). Solar powered automatic drip irrigation system using wireless sensor network technology. *International Research Journal of Engineering and Technology*, 4(7), 722-731.
- [7] Harishankar, S., Kumar, R. S., Sudharsan, K. P., Vignesh, U. & Viveknath, T. (2014). Solar powered smart irrigation system. *Advance in Electric and Electric Engineering*, 4(4), 341-346.
- [8] Murtaza, M. A., Sharma, M., Yadav, R., Chaudhary, R. & Rastogi, K. (2017). Solar powered automatic irrigation system. *International Journal of Engineering Science and Computing*, 7(4), 10719-10722.
- [9] Al Smadi, T. A. (2012). Computer application using low cost smart sensor. *International Journal of Computer Aided Engineering and Technology*, 4(6), 567-579.
- [10] Kumawat, S., Bhamare, M., Nagare, A., Kapadins, A. (2017). Sensor based automatic irrigation system and soil pH detection using image processing. *International Research Journal of Engineering and Technology*, 4(4), 3673-3675.
- [11] Rathod, A. T. & Awate, A. U. (2018). Design and development of automated irrigation system. *International Journal of Innovative Research in Technology*, 5(3), 2349-6002
- [12] Kapse, N., Wadibhasme, H., Sonkure, N., Vikhar, R. & Pandhare, A. (2018). GSM module operated solar powered water pump. *International Journal of New Technology and Research*, 4(3), 154-156.
- [13] Al-Agha, O. I., & Alsmadi, K. A. (2018). Overview of model free adaptive (MFA) control technology. *IAES International Journal of Artificial Intelligence*, 7(4), 165.
- [14] Pavithra, D. S. & Srinath, M. S. (2014). GSM based automated irrigation control system for efficient use of resources and crop planning by using an android mobile. *IOSR Journal of Mechanical and Civil Engineering*, 11(4), 49-55.
- [15] Suman, S., Kumar, S., Sarkar, R. & Ghosh, G. (2017). Solar powered automatic irrigation system on sensing moisture content using Arduino and GSM. *International Journal of Advanced Research in Electronic and Communication Engineering*, 6(6), 549-555.
- [16] Pathan, S. A. & Hate, S. G. (2016) Irrigation system using a sensor and matlab programming. *International Journal of Advanced Research*, 4(5), 320-324.
- [17] Ogidan, O. K., Onile, A. E. & Adegboro, O. G. (2019). Smart irrigation system: a water management procedure. *Agriculture Sciences*, 10(1), 25-31.
- [18] Al Smadi, T. A. (2011). Low cost smart sensor design. *Am. J. Eng. Applied Sci*, 4, 162-168.